

model no. 055-5530-8

**Mastercraft™**

## DRILL PRESS

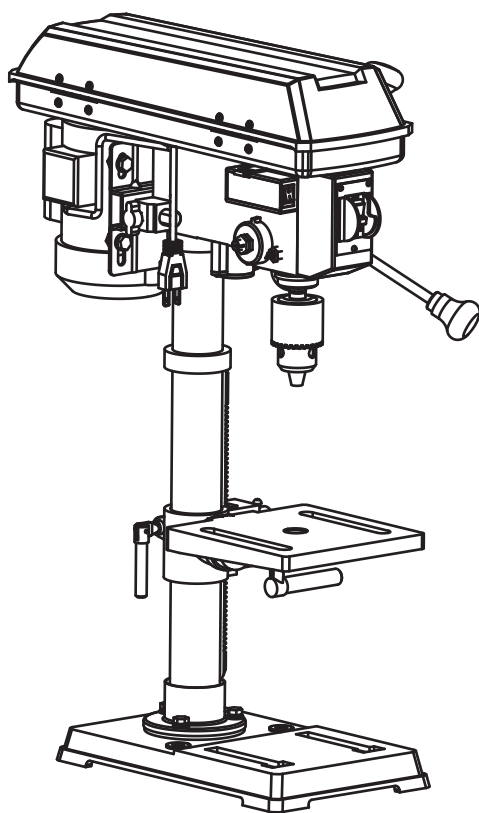

### **IMPORTANT:**

Please read this manual carefully before using this drill press and save it for reference.

**INSTRUCTION  
MANUAL**

**TABLE OF CONTENTS**

Quick Start Guide	4
Specifications	5
Safety Guidelines	6-13
Know Your Drill Press	14-16
Assembly Instructions	17-28
Operating Instructions	29-32
Maintenance	33
Troubleshooting	34
Exploded View	35
Parts List	36-37
Warranty	38

**NOTE:**

If any parts are missing or damaged, or if you have any questions, please call our toll-free helpline at 1-800-689-9928



**SAVE THESE INSTRUCTIONS**

This manual contains important safety and operating instructions. Read all instructions and follow them when using this product.

- Place the column tube (2) on the base (1), align the column support holes with the base holes.
- Install a bolt M8 x 25 (3), a flat washer M8 (4) and a spring washer M8 (5) in each column support hole and tighten with the wrench.  
→ see page 20

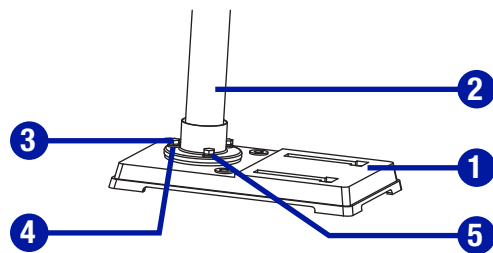

- Lift the drill press head assembly (1) carefully and place the mounting hole of the drill press head onto the top of the column (2). Make sure the head is seated properly on the column.  
→ see page 21

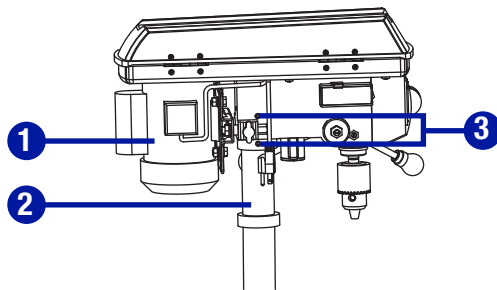

- Mark the desired depth of the hole on the side of the workpiece (1).
- With the switch off, bring the drill bit (2) down until the tip is even with the mark.  
→ see page 30

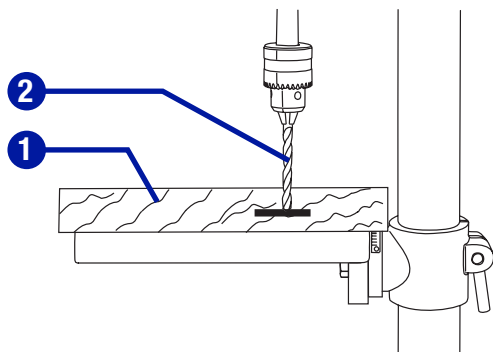

## SPECIFICATIONS

Motor	120 V, 60 Hz, 4.1A
Pulley speeds	620, 1150, 1630, 2180, 3070 RPM (no load)
Table size	7 1/4 X 7 1/4" (18.4 x 18.4 cm)
Base size	13 3/8 X 8 1/4" (34 x 21 cm)
Spindle travel	5 cm
Column diameter	ø5 cm
Max. drilling capacity	5/8" (1,2 cm) diameter
Capacity	5" (12.7 cm) chuck to column 12 3/16" (31 cm) chuck to table 17 1/4" (43.8 cm) chuck to base
Chuck	1/16–5/8" (1.5–16 mm), keyed
Weight	49 lb 8 oz (22.5 kg)

## SAFETY GUIDELINES

This manual contains information that relates to PROTECTING PERSONAL SAFETY and PREVENTING EQUIPMENT PROBLEMS. It is very important to read this manual carefully and understand it thoroughly before using the product. The symbols listed below are used to indicate this information.



### DANGER!

Potential hazard that will result in serious injury or loss of life.



### WARNING!

Potential hazard that could result in serious injury or loss of life.



### CAUTION!

Potential hazard that may result in moderate injury or damage to equipment.

**Note:** The word “**Note**” is used to inform the reader of something the operator needs to know about the tool.

## SAFETY RECOMMENDATIONS

These precautions are intended for the personal safety of the operator and others working with the operator. Failure to follow these instructions may result in a permanent loss of vision, serious personal or even fatal injury, property damage and/or tool damage. Please take time to read and understand the instructions. Safety is a combination of common sense, staying alert, and knowing how your drill press works.

## WORK AREA

- **Keep children away.** Do not let visitors contact tool or extension cord. All visitors should be kept at a safe distance from work area.
- **Keep work areas clean.** Cluttered areas and benches invite accidents.
- **Make workshop childproof.** With padlocks, master switches, or by removing starter keys.
- **Avoid dangerous environments.** Don't use power tools in damp or wet locations. Keep work area well lit. Do not expose power tools to rain. Do not use the tool in the presence of flammable liquids or gases.

## PERSONAL SAFETY

- **Know your power tool.** Read and understand the owner's manual and labels affixed to the tool. Learn the tool's uses and limitations as well as the specific potential hazards particular to this tool.
- **Don't overreach.** Keep proper footing and balance at all times.
- **Stay alert.** Watch what you are doing. Use common sense. Do not operate tool when you are tired. Do not operate while taking medication or while using alcohol or other drugs.



### WARNING!

To avoid mistakes that could cause serious injury, do not plug in the drill press until you have read and understood the following rules.

- **Wear proper apparel.** Do not wear loose clothing, gloves, neckties, rings, bracelets or other jewelry that may get caught in moving parts. Non-slip footwear is recommended. Wear protective hair covering to contain long hair.
- **Always use safety glasses.** Also use face or dust mask if cutting operation is dusty, and ear plugs during extended periods of operation. Everyday eyeglasses have only impact-resistant lenses, they are NOT safety glasses.
- **Guard against electric shock.** Prevent body contact with grounded surfaces. For example: pipes, radiators, ranges, refrigerator enclosures.
- **Disconnect tools from power source,** when not in use, before servicing, when changing blades, bits, cutters, etc.
- **Keep guards in place,** in working order, and in proper adjustment and alignment.
- **Remove adjusting keys and wrenches** when not in use, before servicing and when changing blades, bits, cutters, etc.
- **Reduce the risk of unintentional starting.** Make sure the switch is in the “Off” position before plugging in the tool.
- **Ground all tools.** This tool is equipped with an approved three conductor cord and a three prong grounding-type plug to fit the proper grounding-type receptacle. The green conductor in the cord is the grounding wire. Never connect the green wire to a live terminal.
- **Never stand on tool or its stand.** Serious injury could occur if the tool is tipped or if the cutting tool is accidentally contacted. Do not store materials on or near the tool such that it is necessary to stand on the tool or its stand to reach them.
- **Check damaged parts.** Before further use of the tool, a guard or other part that is damaged should be carefully checked to ensure that it will operate properly and perform its intended function. Check for alignment of moving parts, mounting and any other conditions that may affect the tool's operation. A guard or other part that is damaged should be properly replaced.

## ADDITIONAL SAFETY GUIDELINES FOR DRILL PRESS

### TOOL USE

- **Don't force tool.** It will do the job better and safer at the rate for which it was designed.
- **Use the right tool.** Don't force a small tool or attachment to do the job of a heavy-duty tool. Don't use tool for purpose not intended—for example, don't use a circular saw for cutting tree limbs or logs.
- **Secure work.** Use clamps or vise to hold work. It is safer than using your hand and it frees both hands to operate the tool.



### WARNING!

- All repairs, electrical or mechanical, should be attempted only by trained technicians. Contact the nearest Service Centre, Authorized Service Station or other competent repair service.
- Use only identical replacement parts. Any others may create a hazard.
- The use of any other accessories may create a hazard.

- **Never leave tool running unattended.** Turn power off. Don't leave tool until it comes to a complete stop.

#### TOOL CARE

- **Do not alter or misuse tool.** These tools are precision built. Any alteration or modification not specified is misuse and may result in dangerous conditions.
- **Avoid gaseous areas.** Do not operate electric tools in a gaseous or explosive atmosphere. Motors in these tools normally spark, and this may result in a dangerous condition.
- **Maintain tools with care.** Keep tools sharp and clean for best and safest performance. Follow instructions for lubricating and changing accessories. Inspect tool cords periodically and, if damaged, have repaired by authorized service facility. Inspect extension cords periodically and replace if damaged. Keep handles dry, clean and free from oil and grease.

- **For your own safety, do not operate your drill press until it is completely assembled and installed according to the instructions, and until you have read and understood the following:**

##### 1. Technical specifications

##### 2. Safety guidelines

##### 3. Know your drill press

##### 4. Assembly instructions

##### 5. Operating instructions

##### 7. Maintenance

##### 8. Troubleshooting

##### 9. Stability of the drill press

If there is any tendency of the drill press to tilt or move during use, bolt it to the bench top or to a piece of 3/4" (2 cm) exterior plywood large enough to stabilize the drill press. Bolt the plywood to the underside of the base so it extends beyond the sides of the base. **DO NOT USE PRESSED WOOD PANELS.** They can break unexpectedly. If the workpiece is too large to easily support with one hand, provide an auxiliary support.

##### 10. Location

Use the drill press in a well-lit area and on a level surface, clean and smooth enough to reduce the risk of trips and falls. Use it where neither the operator nor the casual observer is forced to stand in line with a potential kickback.



#### WARNING!

Before connecting the tool to a power source (receptacle, outlet, etc.), be sure voltage supplied is the same as that specified on the nameplate of the tool. A power source with a voltage greater than that specified for the tool can result in serious injury to the user, as well as damage to the tool. If in doubt, **DO NOT PLUG IN THE TOOL.** Using a power source with a voltage less than the nameplate rating is harmful to the motor.

- **11. Protection:** Eyes, hands, ears and body.

#### TO AVOID BEING PULLED INTO THE SPINNING TOOL—

#### DO NOT WEAR: Loose-fitting gloves

Necktie

Loose clothing

Jewelry

#### DO: TIE BACK LONG HAIR

#### ROLL LONG SLEEVES ABOVE ELBOWS

- If any part of your drill press is missing, malfunctioning, has been damaged or broken, such as the motor switch or other operating control, a safety device or the power cord, cease operating the drill press immediately until the particular part is properly repaired or replaced.
- Never place your fingers in a position where they could contact the drill bit or other cutting tool if the workpiece should unexpectedly shift or your hand should slip.
- To avoid injury from parts thrown by the spring, follow the instructions exactly as given and shown in "SPINDLE RETURN SPRING" section.
- To prevent the workpiece from being torn from your hands, spinning on the table, shattering the tool, or being thrown, always support your work so it won't shift or bind to the tool.
  - Always position "backup material" (used beneath the workpiece) to contact the left side of the column.
  - Whenever possible, position the workpiece to contact the left side of the column. If the workpiece is short or the table is tilted, clamp workpiece solidly to the table. Use table slots or clamping ledge around the outside edge of the table.
  - When using a drill press vise, always fasten to the table.
  - Never do any work "free hand" (hand holding a workpiece rather than supporting it on the table), except when polishing.
  - Securely lock head and table support to column, and table to table support, before operating drill press.
  - Never move the head or table support while the tool is running.
  - Before starting the operation, jog the motor switch to make sure the drill bit or other cutting tool does not wobble or cause vibration.
  - If a workpiece overhangs the table such that it will fall or tip if not held, clamp it to the table or provide auxiliary support.
  - Use fixtures for unusual operations to adequately hold, guide and position the workpiece.
  - Use the SPINDLE SPEED recommended for the specific operation and workpiece material. Check the panel inside the pulley cover for drilling information. For accessories, refer to the instructions provided with the accessories.
- Never climb on the drill press table; it could break or pull the entire drill press down on you.
- Turn the motor switch "Off" and unplug from power source when not in operation.
- To avoid injury from thrown work or tool contact, **DO NOT** perform layout, assembly or setup work on the table while the cutting tool is rotating.

## 12. Use only accessories designed for this drill press to avoid serious injury from thrown, broken parts or workpieces.

- a. **WHEN CUTTING LARGE DIAMETER HOLES:** Clamp the workpiece firmly to the table. Otherwise the cutter may grab and spin at high speed. Use only one-piece, cup-type, hole cutters. DO NOT use fly cutters or multi-part hole cutters, as they come apart or become unbalanced in use.
- b. **Drum sanders must NEVER be operated on this drill press at a speed greater than the speed rating of the drum sander.**
- c. **Do not install or use any drill bit that exceeds 7" (17.8 cm) in length or extends 6" (15.2 cm) below the chuck jaws. They can suddenly bend outward or break.**
- d. **Do not use wire wheels, router bits, shaper cutters, circle (fly) cutters or rotary planers on this drill press.**
- e. **Use recommended speed for drill accessory and workpiece material.**
- f. **Accessories must be rated for at least the spindle speed setting of the drill press.** This drill press has five spindle speeds. Check spindle speed setting of the drill press based on the pulley speed chart located inside the pulley housing. Ensure accessories used have a higher speed rating than the current spindle speed setting of the drill press. Accessories running over their rated speed can fly apart and cause injury.

## 13. Direction of feed for drum sanding

- Feed workpiece into a sanding drum or other approved accessory, against the direction of rotation.
- A kickback occurs when workpiece suddenly binds on the cutting edge of the tool and the workpiece is thrown by the cutter in the direction of the cutter's rotation. This can cause serious injury.

## 14. Note and follow the safety warnings and instructions:

For your own safety, read and understand instruction manual before operating drill press:

- Wear safety glasses or safety goggles.
- Do not wear loose fitting gloves, necktie or loose clothing. Tie back long hair.
- Clamp workpiece or brace against column to prevent rotation.
- Use recommended speed for drill accessory and workpiece material.
- Use only recommended accessories.
- Before starting, be certain chuck key is removed from chuck and that motor, head and table are locked.
- Keep pulley cover closed when not making belt adjustments.
- Unplug drill press before making bit/accessory changes, adjustments or repairs.
- Do not expose to rain or use in damp locations.

## 15. This drill press has five speeds: 620 RPM, 1150 RPM, 1630 RPM, 2180 RPM AND 3070 RPM. See inside of guard for specific placement of belt on pulleys.

## 16. Think safety

Safety is a combination of operator common sense and alertness at all times when the drill press is being used.

## USE SAFETY GOGGLES AND EAR PROTECTION:

ALWAYS WEAR EYE PROTECTION THAT CONFORMS WITH CUL REQUIREMENTS. FLYING DEBRIS can cause permanent eye damage.

The tool is loud and the sound can cause hearing damage. Always wear ear protection to help prevent hearing damage and loss. Failure to comply may result in moderate injury.

## USE DUST MASK:

Some dust created by drilling contains chemicals that are known to cause cancer, birth defects or other reproductive harm. Some examples of these chemicals come from lead-based paints, crystalline silica from bricks, cement and other masonry products, arsenic and chromium from chemically treated lumber. To reduce exposure to these chemicals, work in a well-ventilated area with approved safety equipment, such as dust masks that are specially designed to filter out microscopic particles.

## ELECTRICAL SAFETY

### GROUNDING INSTRUCTIONS:

This machine must be grounded while in use to protect the operator from electric shock.

In the event of a malfunction or breakdown, grounding provides a path of least resistance for electric current to reduce the risk of electric shock. This tool is equipped with an electric cord having an equipment-grounding conductor and a grounding plug. The plug must be plugged into a matching outlet that is properly installed and grounded in accordance with all local codes and ordinances.



### WARNING!

Do not allow familiarity (gained from frequent use of your drill press) to become commonplace. Always remember that a careless fraction of a second is sufficient to inflict severe injury.



### CAUTION!

In all cases, verify that the outlet in question is properly grounded. If you are not sure, have a licensed electrician check the outlet.

Do not modify the plug provided. If it will not fit the outlet, have the proper outlet installed by a qualified electrician.

Improper connection of the equipment-grounding conductor can result in a risk of electric shock. The conductor with a green surface, with or without yellow stripes, is the equipment-grounding conductor. If repair or replacement of the electric cord or plug is necessary, do not connect the equipment-grounding conductor to a live terminal.

Check with a qualified electrician or service technician if the grounding instructions are not completely understood, or if in doubt as to whether the tool is properly grounded. Use only three wire extension cords that have three prong grounding plugs and three pole receptacles that accept the tool's plug, as shown in Fig. 1. Repair or replace a damaged or worn cord immediately.

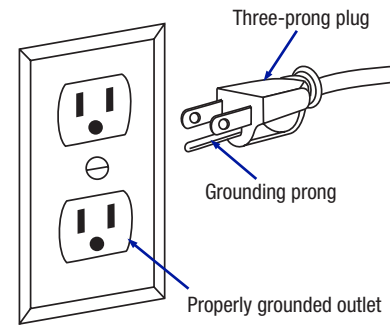

Fig. 1

#### GROUNDING INSTRUCTIONS:

- Make sure the extension cord is in good condition. When using an extension cord, be sure to use one that is heavy enough to carry the current that your product will draw. An undersized cord will cause a drop in line voltage, which will result in loss of power and overheating. The table on the next page shows the correct size to be used according to cord length and nameplate ampere rating. When in doubt, use the next heavier gauge. The smaller the gauge number, the heavier the cord.
- Make sure your extension cord is properly wired and in good condition. Always replace a damaged extension cord, or have it repaired by a qualified person before using it. Protect your extension cords from sharp objects, excessive heat, and damp or wet areas.
- Use a separate electrical circuit for your tools. This circuit must consist of not less than #12 wire with a 20 A time-delayed fuse or a #14 wire with a 15 A time-delayed fuse. Before connecting the motor to the power line, make sure the switch is in the Off position and the electric current is rated the same as the current stamped on the motor nameplate. Running at a lower voltage will damage the motor.



#### WARNING!

- Use the proper extension cord. Make sure to use an extension cord that is heavy enough to carry the current required by the tool. An undersized cord will cause a drop in line voltage, resulting in loss of power and overheating of the tool.
- Use the extension cord only for intended purpose. Do not pull the extension cord to remove it from the power socket.

#### Recommended size for extension cords

AMPERAGE RATING OF THE TOOL (120 V CIRCUIT ONLY)		TOTAL LENGTH OF THE EXTENSION CORD			
		25' (7.6 m)	50' (15.2 m)	100' (30.5 m)	150' (45.7 m)
MORE THAN	NOT MORE THAN	MINIMUM GAUGE FOR THE EXTENSION CORD (AWG)			
0	6	18	16	16	14
6	10	18	16	14	12
10	12	16	16	14	12
12	16	14	12	Not recommended	



#### WARNING!

This tool must be grounded while in use in order to protect the operator from electric shock.

#### NOTE:

Recycle unwanted materials rather than disposing of them as waste. Sort the tool and its components in specific categories and take to the local recycling centre or dispose of them in an environmentally safe way.



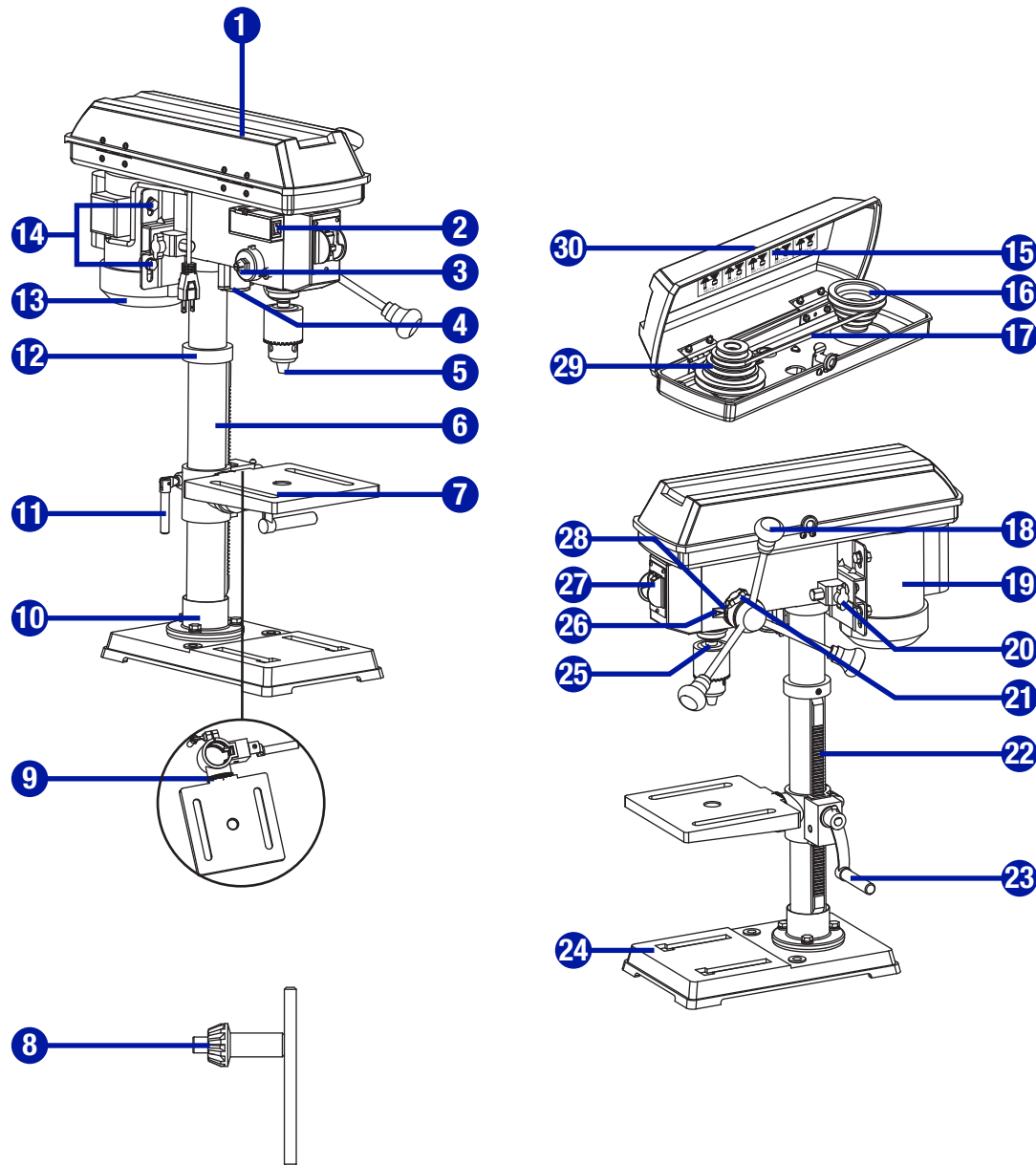

NO.	Description
1	Pulley housing cover
2	LED worklight switch
3	Feed return spring and cover
4	LED worklight
5	Chuck
6	Column
7	Table
8	Chuck key
9	Bevel scale
10	Column support
11	Support lock handle
12	Rack collar
13	Power cord
14	Locking screws
15	Belt/pulley speed chart

NO.	Description
16	Motor pulley
17	Belt
18	Feed handle
19	Motor
20	Tension lock knob
21	Depth tension knob
22	Rack
23	Crank handle
24	Base
25	Quill
26	Pointer
27	On/Off switch
28	Depth scale
29	Spindle pulley
30	Pulley housing screw

**On/Off switch:**

The On/Off switch located on the front of the drill press allows the operator to turn On/Off the drill press easily. To lock the switch in the Off position, remove the safety key from the switch. Place the safety key in a location that is not accessible to children and others who are not qualified to use the tool.

**Spindle speed:**

Five different spindle speeds allow you to drill a wide variety of material including wood, plastic and metal.

**Bevel scale:**

The bevel scale indicates the degree to which the table is tilted.

**Chuck:**

Your drill press features a standard three-jaw type chuck with a self-ejecting chuck key, which prevents accidentally starting the drill press with the key still engaged in the chuck.

**Depth scale:**

A depth scale is located between the pulley housing and feed handles to aid in drilling at desired depths.

**Feed handles:**

Feed handles raise and lower the chuck and bit during the drilling operation.



**Motor:**

Your drill press is equipped with an industrial-duty induction motor for long-lasting, smooth performance.

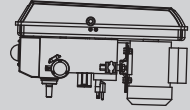
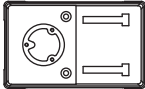
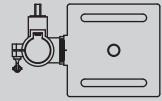
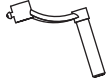
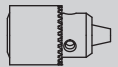

**Table:**





The table of your drill press rotates 360° and bevels up to 45° for angle drilling.

**LED worklight (3.2-3.4 V):**

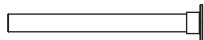

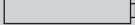
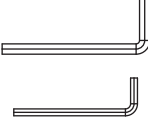
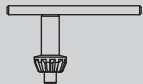

The drill press comes equipped with an LED worklight that lights the work area for more accurate cuts. The worklight turns on with the LED worklight switch.

**PACKAGE CONTENTS**

No	Description	Qty	Illustration
1	Head assembly	1	
2	Base	1	
3	Table/support assembly	1	
4	Crank handle	1	
5	Chuck	1	
6	Feed handles	3	
7	Rack	1	
8	Column/support assembly	1	

No	Description	Qty	Illustration
9	Rack collar	1	
10	Flat washers M8	3	
11	Spring washers M8	3	
12	Bolts M8x25	3	
13	Batteries	2	
14	3 mm/4 mm Hex key	2	
15	Chuck key	1	

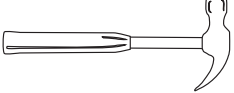
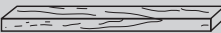
### TOOLS NEEDED FOR ASSEMBLY

Star-head screwdriver		Framing square	
Wrench		Hammer	
Block of wood		Ruler	

### UNPACKING

Do not use this product if any parts of the package contents are already assembled to your product when you unpack it. Package contents are not assembled to the product by the manufacturer and require customer installation. Use of a product that may have been improperly assembled could result in serious personal injury.

- Inspect the tool carefully to make sure no breakage or damage occurred during shipping.
- Do not discard the packing material until you have carefully inspected and satisfactorily operated the tool.
- Remove the protective oil that is applied to table, base and column. Use any ordinary household grease and spot remover.
- Apply a coat of paste wax to the table, column and machined surfaces of base to prevent rust. Wipe all parts thoroughly with a clean, dry cloth.
- If any parts are damaged or missing, please call 1-800-689-9928 for assistance.



### WARNING!

If any parts are damaged or missing, do not operate this tool until the parts are replaced. Use of this product with damaged or missing parts could result in serious personal injury.

- Do not attempt to modify this tool or create accessories not recommended for use with this tool. Any such alteration or modification is misuse and could result in a hazardous condition leading to possible serious personal injury.
- Do not connect to power supply until assembly is complete. Failure to comply could result in accidental starting and possible serious personal injury.
- Risk of injury! Always pull out the mains plug (disconnect the product from its power supply) before commencing work on the product.
- To avoid fire or toxic reaction, never use gasoline, naphtha or similar highly volatile solvents.

**BASE TO COLUMN (Fig. 2)**

- Set the base (1) on the floor.
- Place the column tube (2) on the base (1), align the column support holes with the base holes.
- Install a bolt M8 x 25 (3), a flat washer M8 (4) and a spring washer M8 (5) in each column support hole and tighten with the wrench.

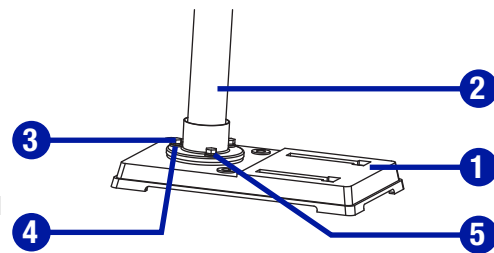

Fig. 2

**TABLE TO COLUMN (Fig. 3–5)**

- Insert the rack (1) into the geared groove of the table support (2). Make sure the worm shaft (3) on the inside of the table support is engaged with the teeth of the rack. The table support should sit at the centre of the rack.
- Slide the table support and rack assembly (1, 2, 3) down together onto the column. Insert the bottom edge of the rack into the lip (4) of the column support. **HOLD IN THIS POSITION** until the next step is completed.
- Place the collar (5) bevel side down over the rack. Tighten the set screw (6) with the 3 mm Allen wrench to hold the rack in position.

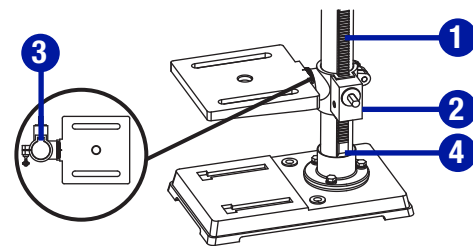

Fig. 3

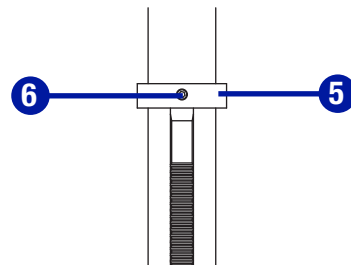

Fig. 4

Make sure there is enough clearance to allow the table to rotate around the column. The collar must sit loosely over the rack and not angled on the column. To avoid column or collar damage, only tighten the set screw enough to keep collar in place (Fig. 4).

- Insert the table support crank handle (7) into the worm gear shaft on the side of the table support (8). Make sure the set screw (9) is aligned on the flat of the shaft and as close to the table support as possible. Tighten the set screw (Fig. 5).
- Position the table in the same direction as the base, and tighten the column lock handle (10).

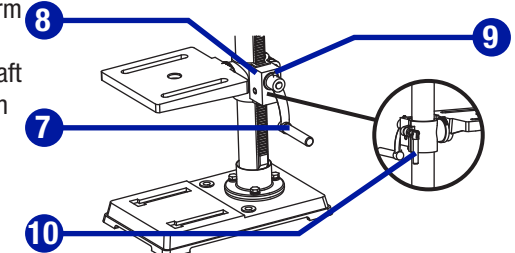

Fig. 5

**DRILL PRESS HEAD TO COLUMN (Fig. 6)**

- Lift the drill press head assembly (1) carefully and place the mounting hole of the drill press head onto the top of the column (2). Make sure the head is seated properly on the column.
- Align the direction of the drill press head with the direction of the base and the table.
- Tighten the two set screws (3) using an Allen wrench.

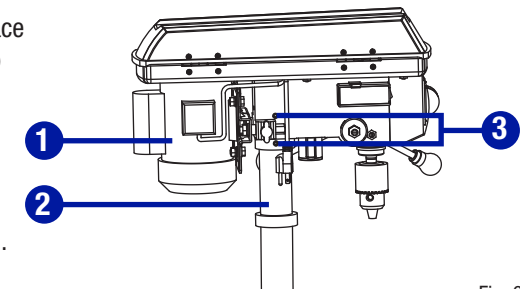

Fig. 6

**FEED HANDLES (Fig. 7)**

- Thread the three feed handle rods (1) into the holes on the feed hub (2).
- Hand tighten.

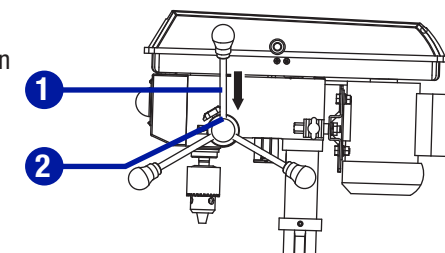

Fig. 7

**WARNING!**

To reduce the risk of injury, never connect plug to power source outlet until all assembly steps are completed.

**NOTE:**

One or two of the feed handles may be removed if an unusually-shaped workpiece interferes with handle rotation.

**LED WORKLIGHT BATTERIES (Fig. 8)**

- Turn off the worklight.
- Push the tab (1) located on the worklight switch cover (2) down and toward you, then remove it.
- Insert two “AAA” batteries in the worklight battery compartment (3).
- Replace the worklight switch cover.

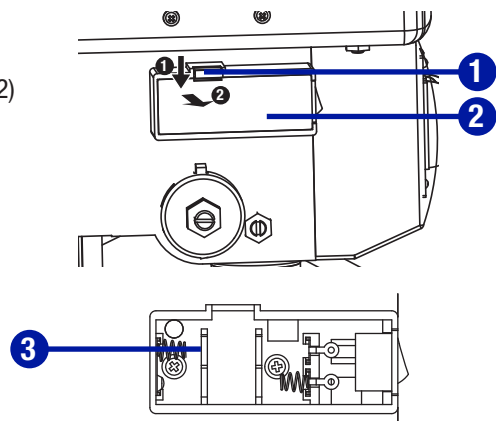

Fig. 8

**MOUNT THE DRILL PRESS (Fig. 9)**

Your drill press must be securely fastened through the mounting holes (1) to a stand or workbench with heavy-duty fasteners. This will prevent the drill press from tipping over, sliding or walking during operation.

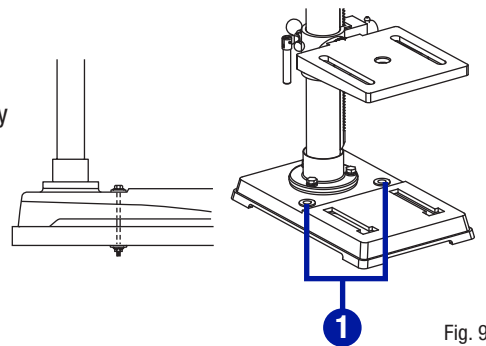

Fig. 9

**INSTALL THE CHUCK (Fig. 10)**

- Inspect and clean the taper hole in the chuck (1) and the spindle (2). Remove all grease, coatings, and particles from the chuck and spindle surfaces with a clean cloth.
- Open the chuck jaws (3) by turning the chuck barrel clockwise by hand. Make sure the jaws are completely recessed inside the chuck.
- Seat the chuck on the spindle by placing a block of wood (4) under the chuck (1) and tapping the wood with a hammer (5) or tap the chuck with a rubber mallet.

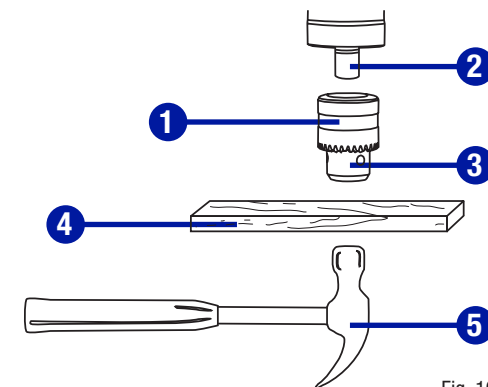

Fig. 10

**REMOVE THE CHUCK (Fig. 11)**

- Turn the feed handles (1) to lower the chuck (2) to the lowest position.
- Place a ball joint separator (not shown) above the chuck and tap it lightly with a hammer (3) to cause the chuck to drop from the spindle.

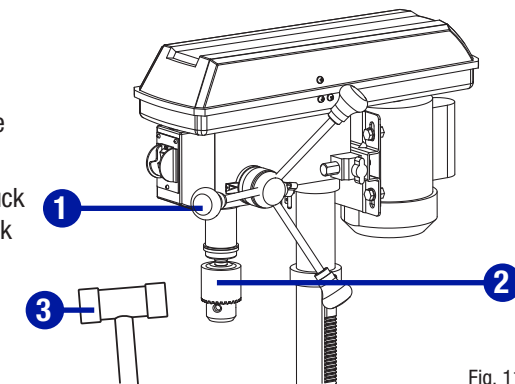

Fig. 11

**CAUTION!**

Remove the LED worklight batteries when the tool is to be stored without use for a few days or more. If left in position, the batteries might leak and damage the LED worklight assembly. Damage due to leaking batteries is not covered under the warranty.

**WARNING!**

Battery may explode or cause injury if disassembled recharged or exposed to fire.

**CAUTION!**

If the stand or workbench has a tendency to move during operation, fasten it securely to the floor.

**CAUTION!**

To avoid damaging the chuck, make sure the jaws are completely recessed into the chuck. Do not use a metal hammer directly to drive the chuck into the spindle.

**NOTE:**

To avoid possible damage, be prepared to catch the chuck as it falls.

**OPERATING ADJUSTMENTS****INSTALL THE BELT (Fig. 12)**

- Open the pulley and belt cover (1).
- Loosen the belt tension lock knobs (2) on both sides of the drill press.
- Slide the motor (3) as close to the drill press head as possible.
- Place a belt (4) on the motor pulley (5) and the spindle pulley (6) in the proper position for the desired speed.
- Pull the motor away from the drill press head until the belt is properly tensioned. Tighten the belt tension lock knobs (2).

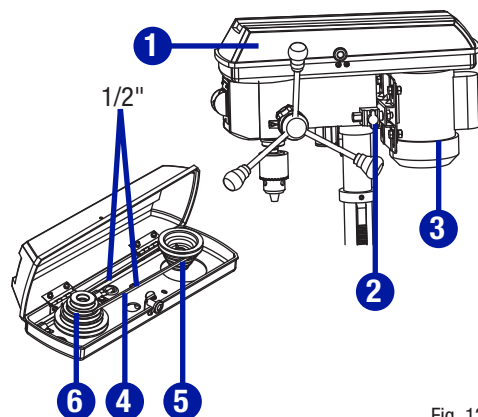

Fig. 12

**ALIGN THE BELT PULLEYS (Fig. 13)**

- Check the alignment of the pulleys with a straight edge (1) (such as a ruler, level, or framing square) by laying the straight edge across the top of the pulleys (2).
- If the pulleys are NOT aligned, release belt tension by loosening the belt tension lock knobs (3) on both sides of the head.
- Loosen the motor mount nuts (4) with an adjustable wrench, and lower or raise the motor until the pulleys are aligned.
- Tighten the motor mount nuts (4) with an adjustable wrench to maintain the position.
- Lock the motor for the proper belt tension and tighten the tension lock knobs (3).

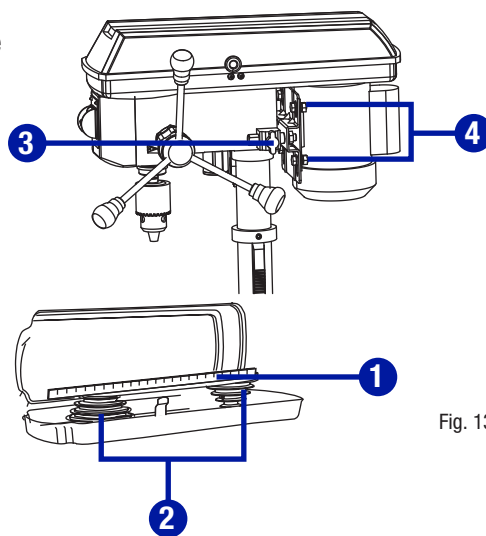

Fig. 13

**NOTE:**

The belt (4) should be tight enough to prevent slippage. Correct tension is set if the belt flexes about 1/2" (13 mm) when thumb pressure is applied at the midpoint of the belt between the pulleys (Fig. 12).

**SPINDLE SPEEDS (Fig. 14)**

This drill press offers five spindle speeds from 620 to 3070 RPM. The highest speed is obtained when the belt is positioned on the largest motor pulley step and the smallest spindle pulley stop.

1	2	3	4	5
RPM 60 Hz ∞ 620	RPM 60 Hz ∞ 1150	RPM 60 Hz ∞ 1630	RPM 60 Hz ∞ 2180	RPM 60 Hz ∞ 3070
BELT:A-1	BELT:B-2	BELT:C-3	BELT:D-4	BELT:E-5

Fig. 14

**ASSEMBLY AND ADJUSTMENTS****ADJUST SPEEDS AND TENSION THE BELT (Fig. 15)**

- Open the drill press pulley cover (1).
- Loosen the belt tension knobs (2) on both sides of the drill press head.
- Pull the motor (3) towards the drill press head.
- Set the belt on the desired steps of the motor pulley (4) and spindle pulley (5) according to the belt positions on the spindle speed chart (Fig. 14).
- Pull the motor away from the drill press head to increase the belt tension. Tighten the tension knobs (2).
- The belt (6) should be tight enough to prevent slippage. Correct tension is set if the belt flexes about 1/2" (13 mm) when thumb pressure is applied at the midpoint of the belt between the pulleys.

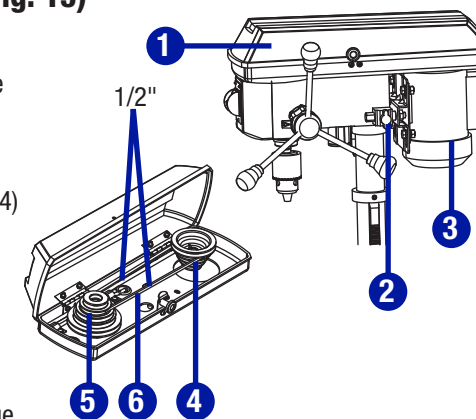

Fig. 15

**CAUTION!**

To reduce the risk of injury, keep pulley cover in place and in proper working order when operating.

**ADJUSTMENTS TO RAISE OR LOWER TABLE (Fig. 16)**

- Raise or lower the table by loosening the column lock handle (1) and turning the crank handle (2) until the table is at the desired height.
- Tighten the table lock handle (1) before drilling.
- Rotate the table around the column by loosening the column lock handle (1) and turning the table around the column to the desired position.
- Tighten the lock handle before drilling.

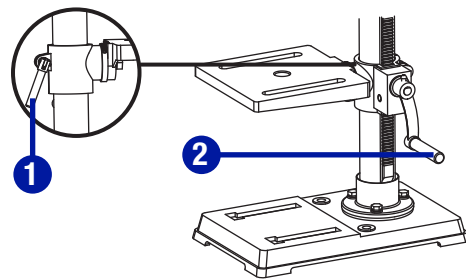

Fig. 16

**TO TILT THE TABLE (Fig. 17)**

The table can be tilted from 0 - 45° to the left and right.

- Loosen the bevel lock bolt (1) with a wrench.
- Tilt the table (2) to the desired angle, using the bevel scale (3) as a basic guide.
- Re-tighten the bevel lock bolt (1).
- To return the table to its original position, loosen the bevel lock bolt. Realign the bevel scale (3) to the 0° setting.
- Tighten the bevel lock bolt (1) with the wrench.

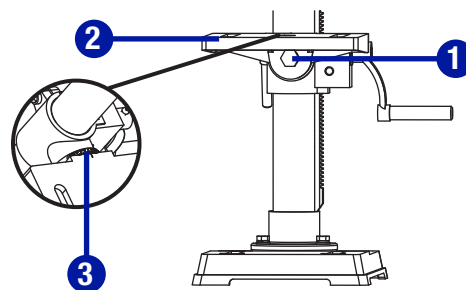

Fig. 17

**TO SQUARE THE TABLE TO THE HEAD (Fig. 18)**

- Insert a 3" (7.6 cm) drill bit (1) into the chuck (2) and tighten.
- Raise and lock the table (3) about 1" (2.5 cm) from the end of the drill bit.
- Place a combination square (4) on the table as shown. The drill bit should be parallel to the straight edge of the square.
- If an adjustment is needed, loosen the bevel lock (5) with a wrench.
- Square the table to the bit by tilting the table.
- Tighten the bevel lock bolt (5) when square.

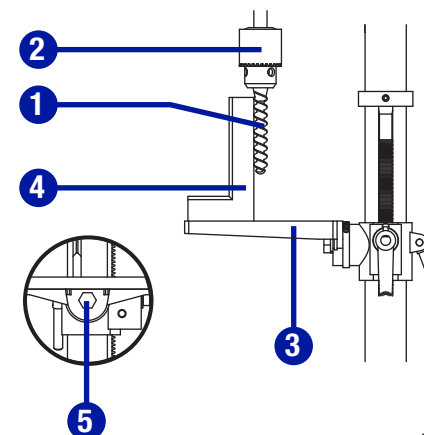

Fig. 18

**DRILLING DEPTH (Fig. 19)**

- To stop the drill at a specific depth for consistent and repetitive drilling, loosen the depth scale lock (1) located on the depth scale hub (2).
- Turn the hub until the pointer (3) is aligned to the desired depth on the scale.
- Tighten the depth scale lock (1). The chuck will stop after traveling downward to the distance selected.

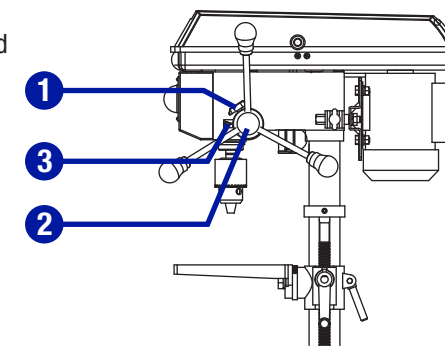

Fig. 19

**SPINDLE RETURN SPRING (Fig. 20)**

The spindle is equipped with an auto-return mechanism. The main components are a spring and a notched housing. The spring was properly adjusted at the factory and should not be readjusted unless absolutely necessary. If it needs to be adjusted, proceed as follows:

- Unplug the drill press.
- Place a screwdriver into the loop (1) to hold the spring in place.
- Loosen the two housing nuts (2) approximately 1/4" (6 mm). Do not remove the nuts from the threaded shaft.
- While firmly holding the spring housing (3), carefully pull it out until it clears the raised notch (4). Turn it until the next notch (5) is engaged with the raised notch (to increase the tension, turn it counter-clockwise; to decrease the tension, turn it clockwise). Tighten the two housing nuts.

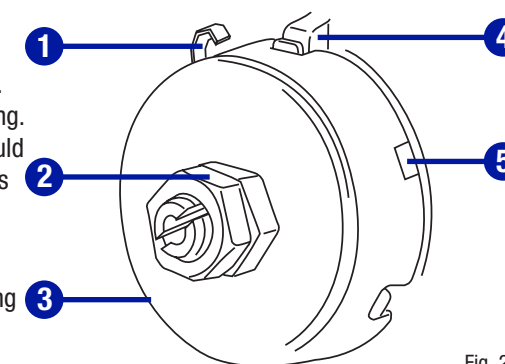

Fig. 20

**NOTE:**

Do not overtighten the two nuts. If the nuts are tightened too much, the movement of the spindle and feed handles will be sluggish.



**ANGULAR PLAY OF THE SPINDLE (Fig. 21)**

Move the spindle to the lowest downward position and hold in place. With your other hand, try to make it revolve around its axis with a side motion. If there is too much play, proceed as follows:

- Loosen the lock nut (1).
- Turn the screw clockwise to eliminate the play but without obstructing the upward and downward motion of the spindle (a little bit of play is normal).
- Tighten the lock nut (1).

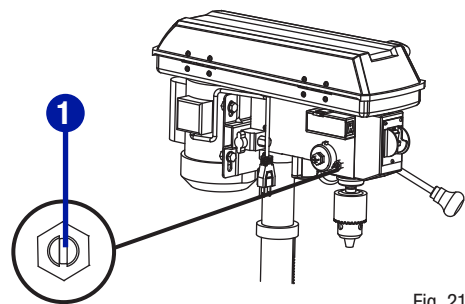

Fig. 21

**INSTALL DRILL BITS (Fig. 22)**

- Place the chuck key (1) into the side keyhole of the chuck (2), meshing the gear teeth (3).
- Turn the chuck key counter-clockwise to open the chuck jaws (4).
- Insert a drill bit into the chuck far enough to obtain maximum gripping of the chuck jaws.
- Centre the drill bit in the chuck jaws before final tightening of the chuck.
- Use the chuck key for the final tightening to make sure the drill bit will not slip while drilling.

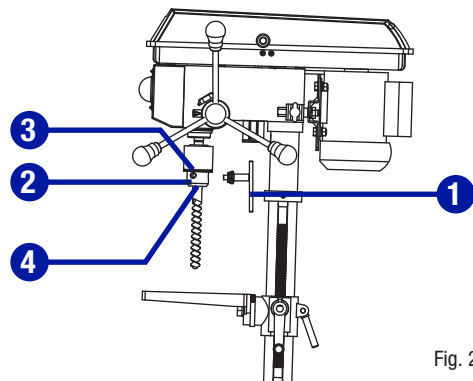

Fig. 22

**ON/OFF SWITCH (Fig. 23)**

- To turn the drill press On, insert the safety key (1) into the switch housing (2). As a safety feature, the switch cannot be turned On without the key.
- Flip the switch upward to the On position.
- To turn the drill press Off, move the switch to the down position.
- To lock the switch in the Off position, remove the safety key from the switch. Store the key in a safe place.

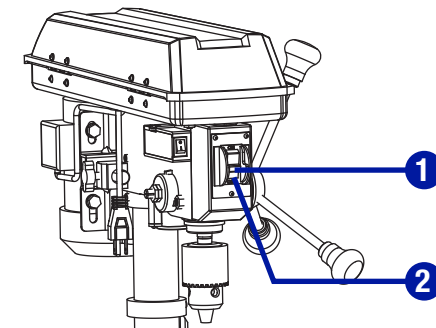

Fig. 23

**LED WORKLIGHT SWITCH (Fig. 24)**

The LED worklight switch (1) is located on the left side of the drill press housing.

- To turn the LED worklight On, press the button "1".
- To turn the LED worklight Off, press the button "0".

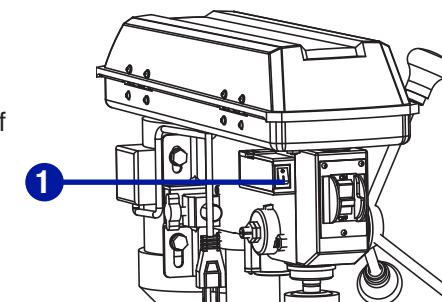

Fig. 24

**POSITION THE TABLE AND WORKPIECE (Fig. 25)**

Always place a piece of backup material (1) (wood, plywood, etc.) on the table underneath the workpiece (2). This will prevent splintering on the underside of the workpiece as the drill bit breaks through. To keep the material from spinning out of control, it must contact the left side of the column as illustrated, or be clamped to the table.

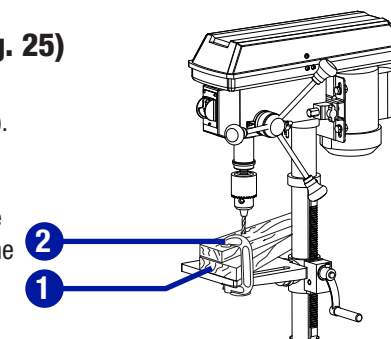

Fig. 25

**NOTE:**

For small workpieces that cannot be clamped to the table, use a drill press vise (optional accessory, not included). The vise must be clamped or bolted to the table to avoid injury.

**WARNING!**

- To reduce the risk of injury, only use the chuck key provided with this drill press or a duplicate of it. This chuck key is self-ejecting and will "pop" out of the chuck when you let go. This action is designed to help prevent throwing of the chuck key from the chuck when power is turned "on". Do not use any other key as a substitute; order a new one if damaged or lost.
- To reduce the risk of injury, make sure the chuck key is removed from the chuck before starting any drilling operation.

**WARNING!**

- To reduce the risk of injury, and the workpiece and the backup material from being torn from your hand while drilling, position them to the left side of the column. If the workpiece and the backup material are not long enough to reach the column, clamp them to the table. Failure to do this could result in personal injury.
- To reduce the risk of injury, make sure the chuck key is removed from the chuck before starting any drilling operation.



**DRILLING A HOLE**

Use a centre punch or sharp nail to dent the workpiece where you want the hole. With the switch Off, bring the drill bit down to the workpiece, lining it up with the hole location. Turn the switch On and pull down on the feed handles with only enough effort to allow the drill to cut.

- Feeding too slowly might cause the drill bit to burn.
- Feeding too rapidly might stop the motor, causing the belt or drill to slip, tearing the workpiece loose, or breaking the drill bit.
- For deeper cuts, drill into the workpiece about 1/4" (6.4 mm) and raise the drill bit out of the workpiece. This will clear chips out of the hole. Drill again another 1/4" (6.4 mm) and raise the drill bit out of the hole to clear debris and chips. Repeat until finished drilling the hole. Practice with scrap material to get the feel of the machine before attempting to do any regular drilling operation.
- When drilling metal, it will be necessary to lubricate the tip of the drill with oil to prevent overheating the drill bit.

**DRILLING TO A SPECIFIC DEPTH**

Drilling a blind hole (not all the way through the workpiece) to a given depth can be done in two ways.

**WORKPIECE METHOD (Fig. 26)**

- Mark the desired depth of the hole on the side of the workpiece (1).
- With the switch off, bring the drill bit (2) down until the tip is even with the mark.
- Hold the feed handle at this position.
- Lock the depth scale lock knob. The chuck and the drill bit will now be stopped at the distance selected on the depth scale.

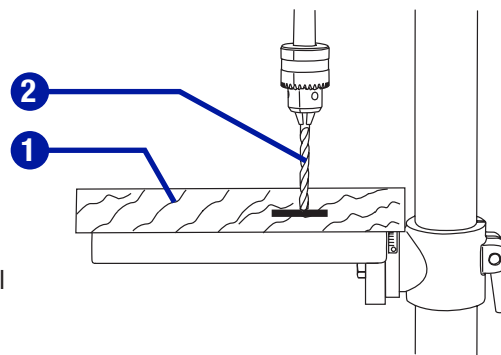

Fig. 26

**DEPTH SCALE METHOD (Fig. 27)**

- With the switch (1) Off, turn the feed handle (2) until the drill bit tip (3) slightly touches the top of the workpiece (4).
- Hold the feed handles in that position.
- Loosen the depth lock knob (5).
- Spin the depth scale hub (6) until the desired drilling depth is at the scale pointer.
- Lock the depth lock knob. The chuck and drill bit will now drill into the workpiece only to the distance selected on the depth scale.

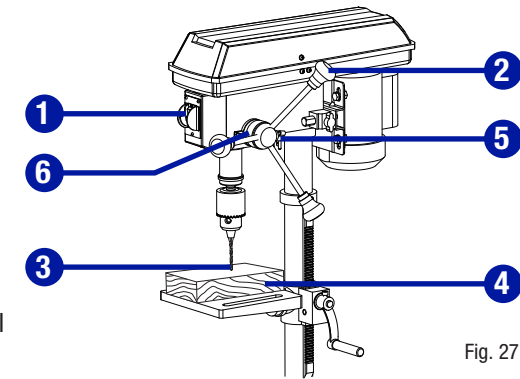

Fig. 27

**GENERAL DRILLING GUIDELINES****DRILLING SPEEDS**

Important factors when determining the best drilling speed:

- Type of material
- Size of the hole to be drilled
- Type of drill bit or cutter
- Desired quality of the cut

Remember, smaller drill bits require greater speed than larger drill bits. Softer materials require greater speed than harder materials.

**DRILLING METAL**

- Use metal-piercing twist drill bits.
- It is always necessary to lubricate the tip of the drill with oil to prevent overheating the drill bit.
- All metal workpieces should be clamped down securely. Any tilting, twisting, or shifting causes a rough drill hole and increases the potential of drill bit breakage.
- Never hold a metal workpiece with your bare hands. The cutting edge of the drill bit may seize the workpiece and throw it, causing serious injury. The drill bit will break if the metal piece suddenly hits the column.
- If the metal is flat, clamp a piece of wood under it to prevent turning. If it cannot be laid flat on the table, then it should be blocked and clamped.

**WARNING!**

To reduce the risk of injury, make sure the chuck key is removed from the chuck before starting any drilling operation.

**DRILLING WOOD**

- Brad point bits are preferred. Metal piercing twist bits may be used on wood.
- Do not use auger bits. They turn so rapidly that they lift the workpiece off the table and whirl it around.
- Always protect the drill bit by positioning the table so the drill bit will enter the centre hole when drilling through the workpiece.
- To prevent splintering, feed slowly when the bit is about to cut through to the backside of the workpiece.
- To reduce splintering and protect the point of the bit, use scrap wood as a backing or a base block under the workpiece.

**FEEDING THE BIT**

- Pull down on the feed handles with only enough force to allow the drill bit to cut.
- Feeding too rapidly might stall the motor, cause the belt to slip, damage the workpiece, or break the drill bit.
- Feeding too slowly will cause the drill bit to heat up and burn the workpiece.

**GENERAL MAINTENANCE**

Frequently blow out or vacuum sawdust or metal chips that accumulate in and on the motor, pulley housing, table and work surface.

A coat of furniture-type paste wax applied to the table, column, and machined parts of the base will help to keep these surfaces clean.

The ball bearings in the spindle and the V-belt pulley assembly are greased and permanently sealed. Pull the spindle down and oil the spindle sleeve moderately every three months.

**WARNING!**

To reduce the risk of injury, turn power switch OFF and remove plug from the power source outlet before doing maintenance on or lubricating your drill press.

**CAUTION!**

Certain cleaning agents and solvents damage plastic parts. Some of these are: gasoline, carbon tetrachloride, chlorinated cleaning solvents, ammonia and household detergents that contain ammonia. Avoiding use of these and other types of cleaning agents minimizes the probability of damage.

To avoid shock or fire hazard, if the power cord is worn, cut or damaged in any way, have it replaced immediately.

**WARNING!**

All repairs, electrical or mechanical, should be attempted only by trained technicians. Use only identical replacement parts; any other may create a hazard.

**TROUBLESHOOTING**

PROBLEM	Possible Causes	Solution
Will not start.	<ul style="list-style-type: none"> <li>• Power cord is not plugged in.</li> <li>• Fuse or circuit breaker ripped.</li> <li>• Cord damaged.</li> <li>• Misaligned guides.</li> </ul>	<ul style="list-style-type: none"> <li>• Plug in.</li> <li>• Replace fuse or reset tripped circuit breaker.</li> <li>• Have cord replaced by a qualified electrician.</li> <li>• Have switch replaced by a qualified service technician.</li> </ul>
Does not come up to speed.	<ul style="list-style-type: none"> <li>• Extension cord too light or too long.</li> <li>• Low house voltage.</li> </ul>	<ul style="list-style-type: none"> <li>• Replace with adequate cord.</li> <li>• Contact your electric company.</li> </ul>

TROUBLESHOOTING

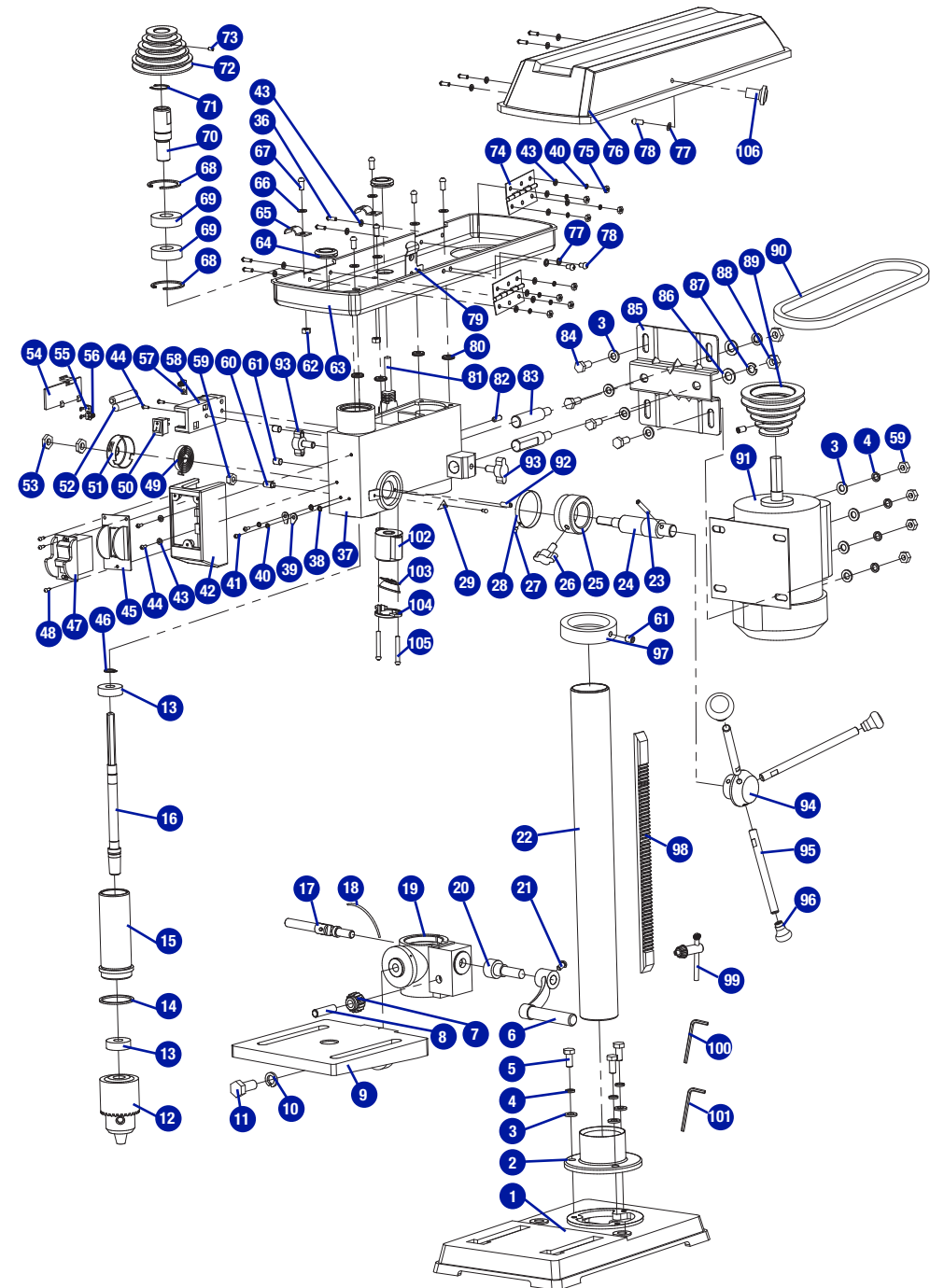

EXPLODED VIEW

## PARTS LIST

No	Description	Qty	No	Description	Qty
1	Base	1	38	Gear pad	2
2	Column support	1	39	Earthing pin	2
3	Flat washer	11	40	Spring washer	10
4	Spring washer	7	41	Screw	4
5	Bolt	3	42	Switch box	1
6	Crank handle	1	43	Flat washer	18
7	Gear	1	44	Screw	2
8	Pin sleeve	1	45	Fixed plate	1
9	Working table	1	46	Spring ring	1
10	Spring washer	1	47	Self-locking switch	1
11	Bolt	1	48	Screw	3
12	Chuck	1	49	Loop spring	1
13	Bearing	2	50	Switch	1
14	Buffer washer	1	51	Spring cap	1
15	Axis sleeve	1	52	Battery	2
16	Axis	1	53	Hex thin nut	2
17	Lock handle	1	54	Cover	1
18	Bevel scale	1	55	Electrode (B)	1
19	Support	1	56	Electrode (A)	1
20	Rail	1	57	Electrodes (B)	1
21	Screws	1	58	Box for battery	1
22	Column	1	59	Hex nut	5
23	Elastic cylindrical pin	1	60	Screw	1
24	Axis	1	61	Screw	3
25	Scale plate	1	62	Hexagon nut	2
26	Knob	1	63	Lower guard	1
27	Rivet	1	64	Coil protection	2
28	Scale label	1	65	Pin	2
29	Pointer	1	66	Flat washer	6
36	Screw	10	67	Screw	6
37	Body	1	68	Spring ring	2

No	Description	Qty	No	Description	Qty
69	Axis	2	88	Hex nut	2
70	Axis sleeve	1	89	Motor pulley	1
71	Spring ring	1	90	Belt	1
72	Pulley	1	91	Motor	1
73	Screw	2	92	Worm pin	1
74	Hinge	2	93	Handle	2
75	Hex nut	8	94	Base for feed handle	1
76	Upper guard	1	95	Rail for feed handle	3
77	Flat washer	3	96	Ball for feed handle	3
78	Screw	3	97	Rack collar	1
79	Lock	1	98	Rack	1
80	Shock washer	4	99	Chuck key	1
81	Power cord	1	100	Allen wrench	1
82	Positioned pin	1	101	Allen wrench	1
83	Connected axis	2	102	Light box	1
84	Bolt	4	103	LED light	1
85	Base board	1	104	Light box cover	1
86	Flat washer	2	105	Bolt	2
87	Spring washer	2	106	knob	1

### 3-Year Limited Warranty

This Mastercraft product is guaranteed for a period of **3 years** from the date of original retail purchase against defects in workmanship and materials, except for the following component:

Component A: Accessories, which are guaranteed for a period of 1-year from the date of original retail purchase against defects in workmanship and materials.

Subject to the conditions and limitations described below, this product, if returned to us with proof of purchase within the stated warranty period and if covered under this warranty, will be repaired or replaced (with the same model, or one of equal value or specification), at our option. We will bear the cost of any repair or replacement and any costs of labour relating thereto.

#### These warranties are subject to the following conditions and limitations:

- a. a bill of sale verifying the purchase and purchase date must be provided;
- b. this warranty will not apply to any product or part thereof which is worn or broken or which has become inoperative due to abuse, misuse, accidental damage, neglect or lack of proper installation, operation or maintenance (as outlined in the applicable owner's manual or operating instructions) or which is being used for industrial, professional, commercial or rental purposes;
- c. this warranty will not apply to normal wear and tear or to expendable parts or accessories that may be supplied with the product that are expected to become inoperative or unusable after a seasonable period of use;
- d. this warranty will not apply to routine maintenance and consumable items such as, but not limited to, fuel, lubricants, vacuum bags, blades, belts, sandpaper, bits, fluids, tune-ups or adjustments;
- e. this warranty will not apply where damage is caused by repairs made or attempted by others (i.e. persons not authorized by the manufacturer);
- f. this warranty will not apply to any product that was sold to the original purchaser as a reconditioned or refurbished product (unless otherwise specified in writing);
- g. this warranty will not apply to any product or part thereof if any part from another manufacturer is installed therein or any repairs or alterations have been made or attempted by unauthorized persons;
- h. this warranty will not apply to normal deterioration of the exterior finish, such as, but not limited to, scratches, dents, paint chips, or to any corrosion or discolouring by heat, abrasive and chemical cleaners; and
- i. this warranty will not apply to component parts sold by and identified as the product of another company, which shall be covered under the product manufacturer's warranty, if any.

#### Additional Limitations

This warranty applies only to the original purchaser and may not be transferred. Neither the retailer nor the manufacturer shall be liable for any other expense, loss or damage, including, without limitation, any indirect, incidental, consequential or exemplary damages arising in connection with the sale, use or inability to use this product.

#### Notice to Consumer

This warranty gives you specific legal rights, and you may have other rights, which may vary from province to province. The provisions contained in this warranty are not intended to limit, modify, take away from, disclaim or exclude any statutory warranties set forth in any applicable provincial or federal legislation.

**This product is not meant for industrial or commercial purposes. This product is for household projects, read manual carefully**

Made in China

Imported by Mastercraft Canada Toronto, Canada M4S 2B8